

GOER-sponsored IT Training

Presentation to the NYS Forum

Executive Committee

June 11, 2010

Moses Kamy, CIO and

Carolyn Peterson-Vaccaro, Director

Workforce and Organizational Development

Governor's Office of Employee Relations



IT in NYS – Where we have come

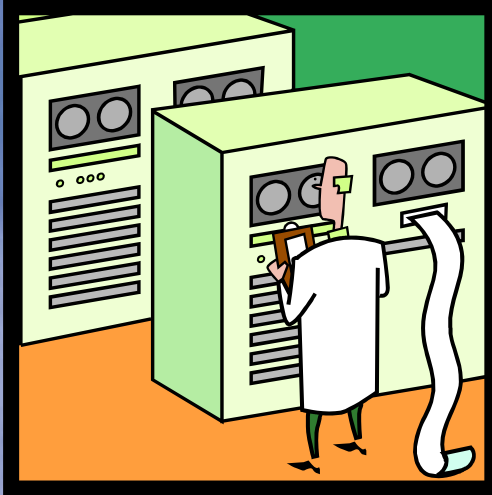

In just 20 years, agencies have gone from massive mainframe systems to massive amounts of data stored on chips.....

Our email communications have gone from dumb terminals to transmission through the internet.

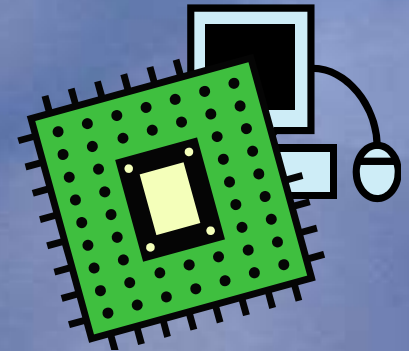

IT in NYS – Where we have come

IT Titles

- Electronic Computer Operator, Grade 10 – May 7, 1959
- By 1963, there were a total of 18 titles in the IT occupation with grades ranging from Grade 10 to Grade 31.
- By 1970, the number of IT titles expanded to approximately 30 titles with grades ranging from Grade 10 to Grade 31.
- **We now have about 74 IT Titles !**



IT in NYS – Where we have come THEN – Mainframe Environment

T4

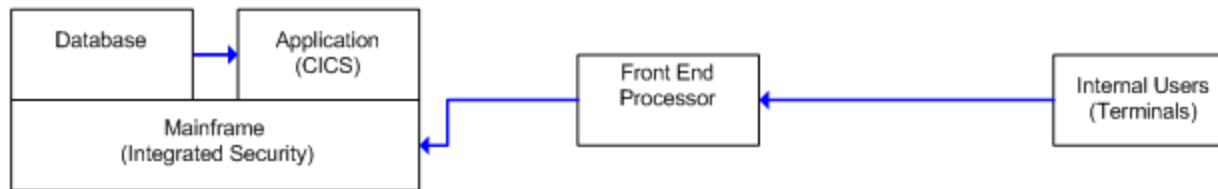

IT in NYS – Where we have come from NOW - TIER Architecture

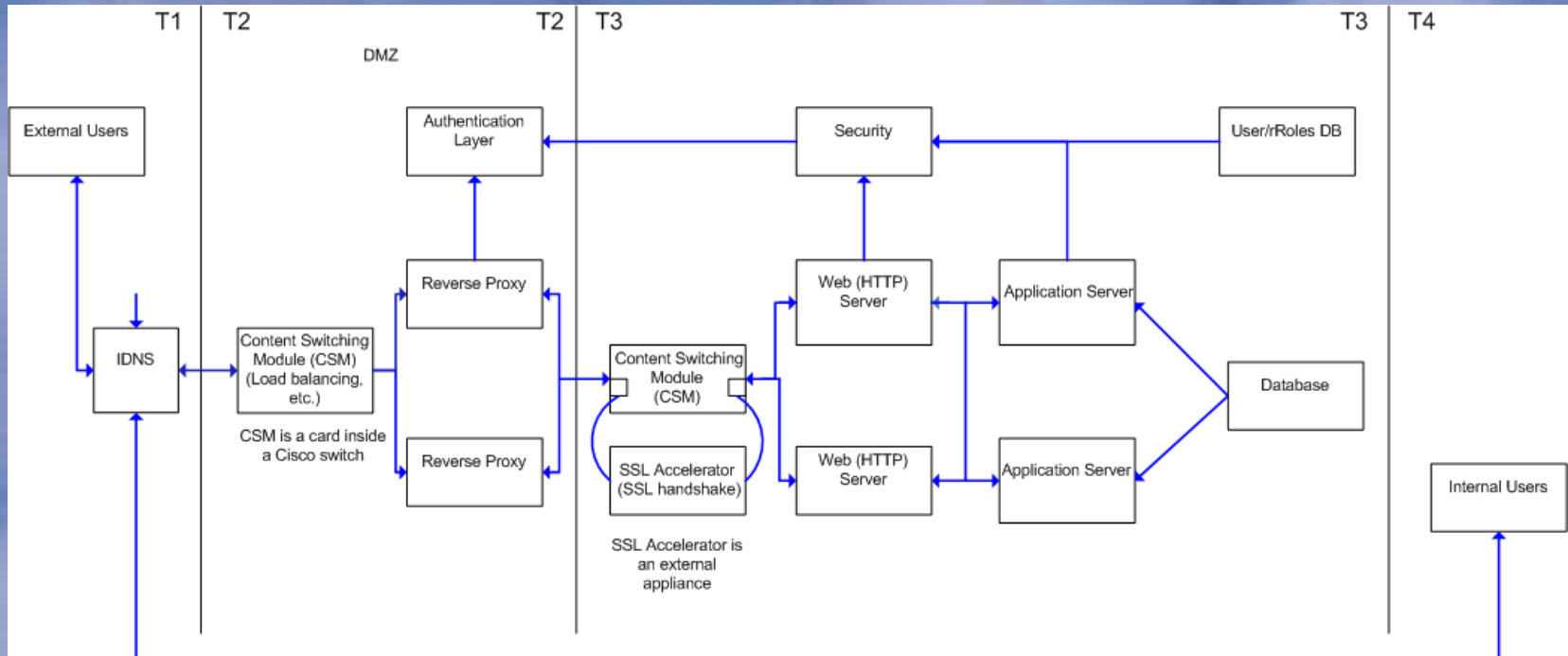

IT Training in the beginning: Catch as Catch can!



Back in the day..... Just 15 or so years ago much learning was because a staff person was so motivated and interested.oftentimes the most expertise would be from someone in a totally unrelated title to IT.

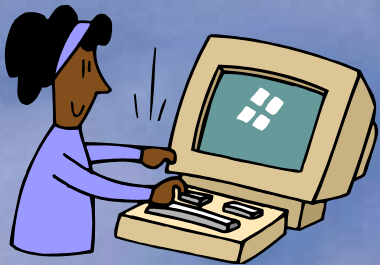

Today's IT

We have now moved from mainframes to stand alone PCs to Client-Server environments using LANs and the internet!

The changes have introduced complexities and new skill requirements to deal with issues like:

- ❖ Connectivity
- ❖ Firewalls
- ❖ Proxy Servers



Training and Development Programs for the New York State Workforce

GOER and its Labor/Management Partners

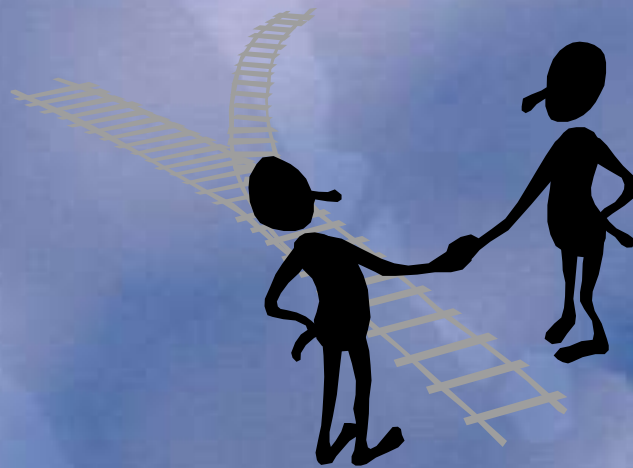

June 11, 2010



Cooperative Vision



“Capitalize on existing resources, augment services where they are minimal, develop new resources.”

*“Coming together is the beginning.
Keeping together is progress.
Working together is success.”*

- Henry Ford



Partnerships and Collaborations



- NYS and PEF - Professional Development Committee (PDC)
- OFT/CIO
- Training Directors Roundtable
- NYS Forum
- CIO Council
- Rockefeller College – PDP
- NYS/CSEA Partnership
- Career Mobility Office (CMO)



Funding Sources

- Funding for all training and development activities at GOER comes from the collective bargaining agreements.
- The Workforce and Organizational Development Unit's (WODU) funding is primarily through Article 15 of the CBA with PEF and is administered by the PDC.
- WODU also receives dollars from the CBA with CSEA and through the M/C Pay Bill.



Training and Development Programs for the NYS Workforce



Coordinated to Benefit Both Agencies and Employees

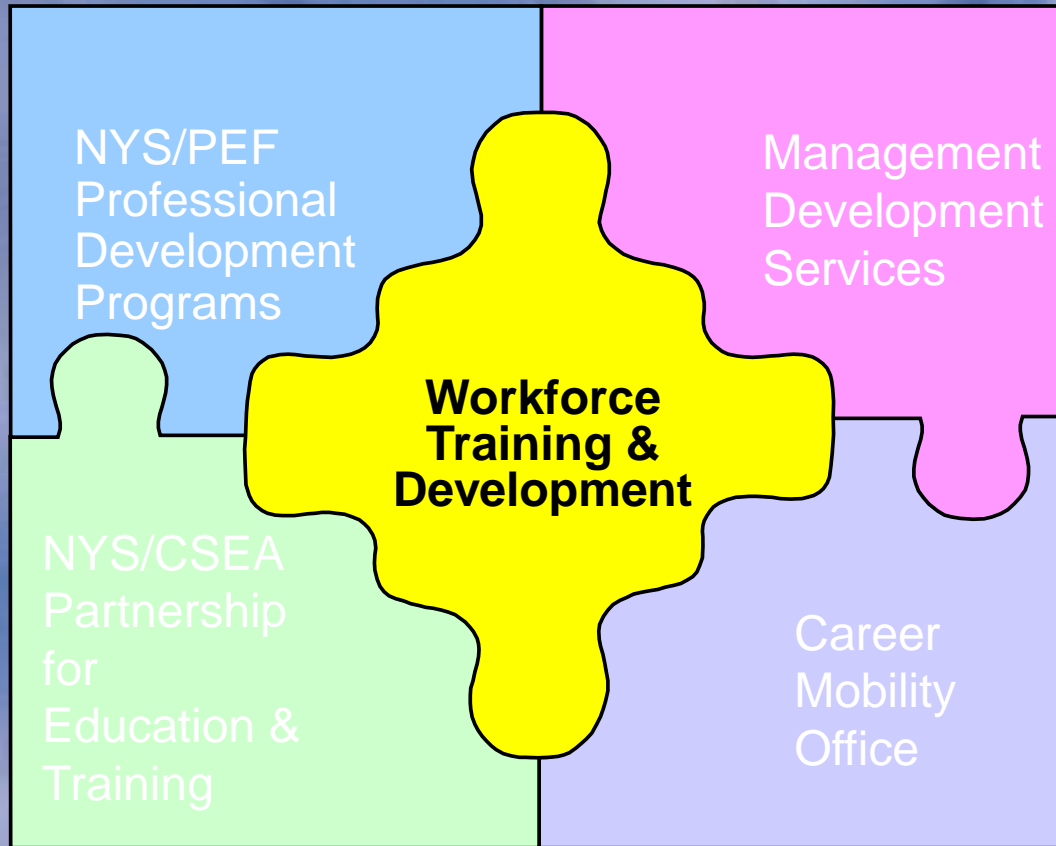

Career Mobility Office (CMO)

- **Target Audience**
 - State Workforce
- **Programs and Services**
 - Career Continuity
 - Career Tools and Resources
 - Career Counseling
 - Career Development

Funded by NYS/CSEA, NYS/PEF,
GOER and Civil Service

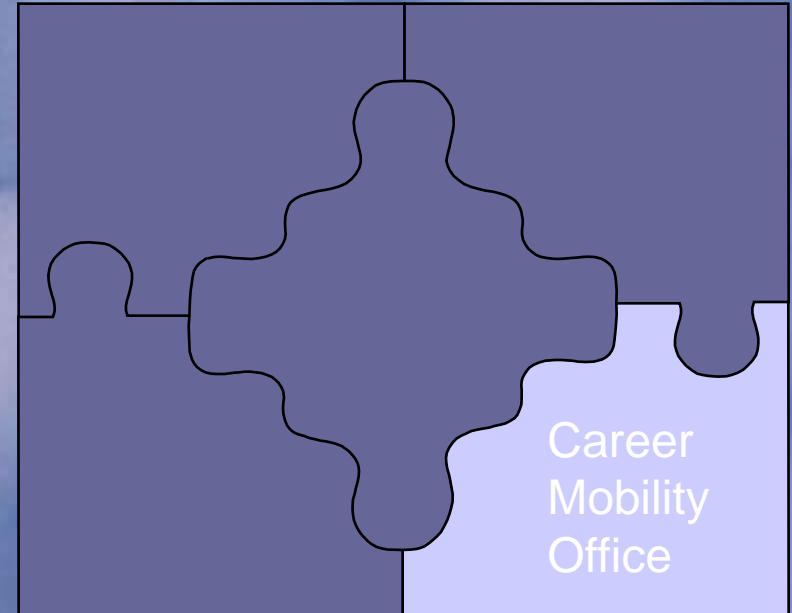



Career Mobility Office

Need Direction?
We can lend a hand!

CMO Home

News/Calendar

Employee Services

Agency Services

GOT-IT

Workshops

Glossary Of Titles - Inquiry Tool (GOT-IT)

Getting Started

Title Search

Agency

GOT-IT is best viewed with [Internet Explorer 5.0 or higher](#), or [Netscape 5.0 or higher](#).

Glossary Of Titles - Inquiry Tool (GOT-IT) is an internet based program that allows State employees to learn more about job titles within the State. GOT-IT has four different search mechanisms that will provide information on specific titles, agencies, occupations and geographics.



NYS/PEF Professional Development Programs

- **Target Audience**
 - PS&T Bargaining Unit Employees
- **Programs and Services**
 - Professional Development Workshops
 - Tuition Assistance
 - Agency Training Grants

Funded by NYS and PEF

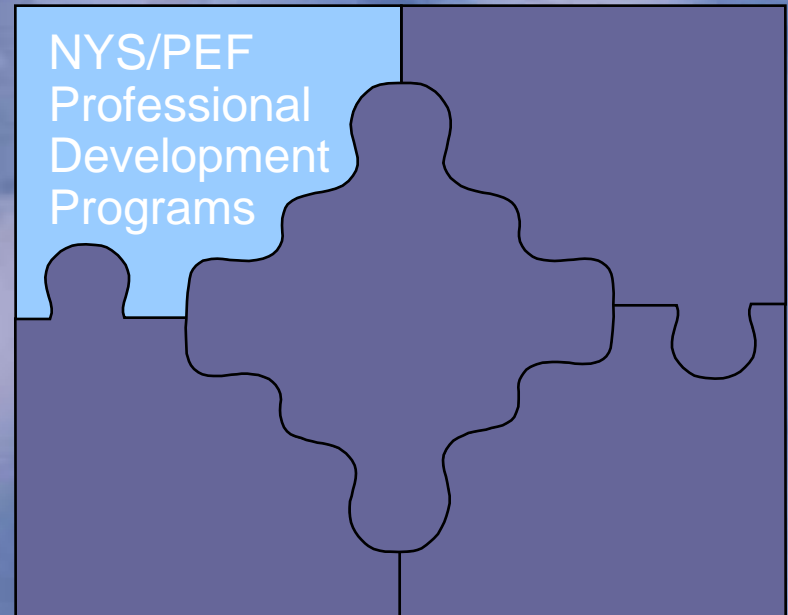

NYS/PEF Professional Development Committee (PDC)

- **Programs and Services**
 - Professional Development Workshops – PSWP
 - Oracle 11g Certification -
 - IT Focus Groups
 - Successful Web Communications
 - Tuition Assistance – PSTP Voucher and WSR (Workshop and Seminar Reimbursement – formerly VALT)
 - Binghamton Online Courses
 - KnowledgeBank (SkillsSoft) project through OFT



Statewide Programs for Training and Employee Development

- Shared commitment by State and public sector unions
- Constant change in all of our work
- IT Skills Survey shaped future offerings
- Current offerings of interest now



Goals

- Enhance technology skills of the government workforce
- Reduce training costs
- Increase staff retention
- Provide more online (eLearning) training
- Reduce reliance on consultants



NYS/CSEA Partnership for Education and Training

- **Target Audience**
 - ASU, ISU, OSU and DMNA Bargaining Unit Employees
 - **Programs and Services**
 - Workforce Planning and Assessment
 - Training and Development
 - Labor-Management Services
 - Grants
 - Educational Advisement
 - Tuition Benefits
- Funded by NYS/CSEA

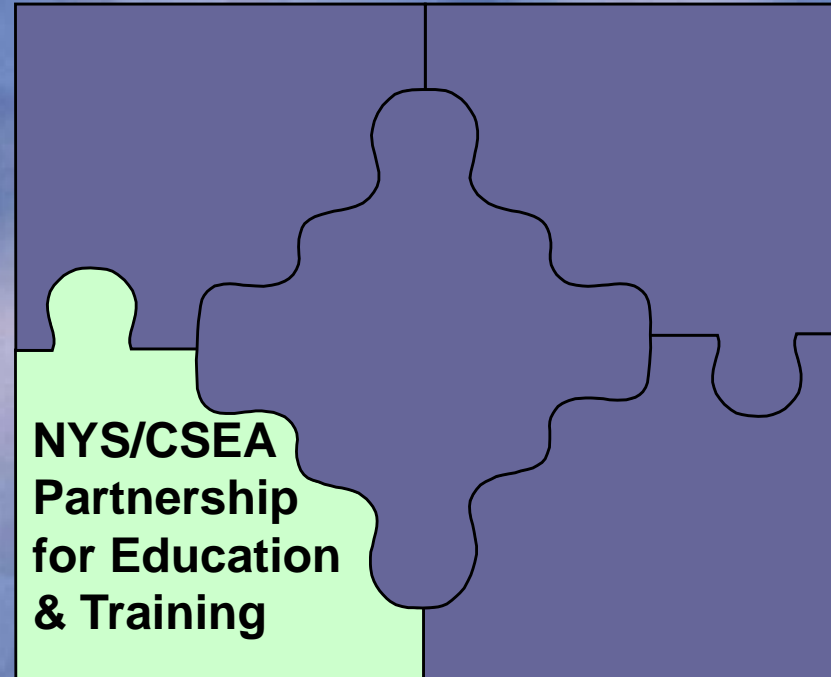

Workforce Training & Development

- **Target Audience**
 - State Workforce
- **Programs and Services**
 - Workplace skills
 - State Policies
 - Supervisory and Management Development

Funded by NYS/CSEA, NYS/PEF,
GOER



Approaches and Methods

- On-Line Training
- Tool Kits
- Resource Library
- Classroom training

Blended learning combines
approaches

- Job Aides
- Networks and learning groups
- Consultants & contractors



Benefits of E-learning

- Through NYS-Learn and then e-NYS-Learn so agencies can track participation
- Anywhere, anytime
- Reduced training costs
- Higher retention of content through self-paced learning
- Reduced learning time
- Consistency
- Measurement
- Satisfaction



New Online Offerings: Cyber Security Awareness Training

New York State
Office of Cyber Security & Critical Infrastructure Coordination

Cyber Security Awareness Training

Provided by
Multi-State Information Sharing & Analysis Center

Internet Security and Malicious Code: Lesson 1 6 of 12

Mail

Favorite Folders

- Inbox
- Unread Mail
- For Follow Up
- Sent Items

All Mail Folders

- Mailbox - Suzanne
 - Deleted Items (41)
 - Drafts
 - Inbox
 - folder 1
 - folder 2
 - folder 3
 - folder 4
 - folder 5
 - folder 6
 - folder 7
 - folder 8
 - Junk E-mail
 - Outbox
 - Sent Items

Inbox

Arranged By: Date

Today

- Chris
moving notice for contacts

Yesterday

- Courtney
RE: production script

Last Week

- David
updated storyboards
- Tracy
Move Update

Three Weeks Ago

- Patti
Pics

E-Mail

- ✓ Common way to spread malicious code
- ✓ Special care required

Exit Help Glossary Menu Subtitles on/off

Pause Back Replay Next



New Online Offerings: Service Oriented Architecture



State of New York
Governor's Office of Employee Relations

Service-Oriented Architecture for New York State

Online Learning Center

EXIT

Introduction

What Sponsors
Need to Know

SOA
Advantages

Business
Processes and
SOA

SOA in your
Department

Module Review

Sponsors

SOA Advantages: Helping New Yorkers *The Right Help at the Right Time*

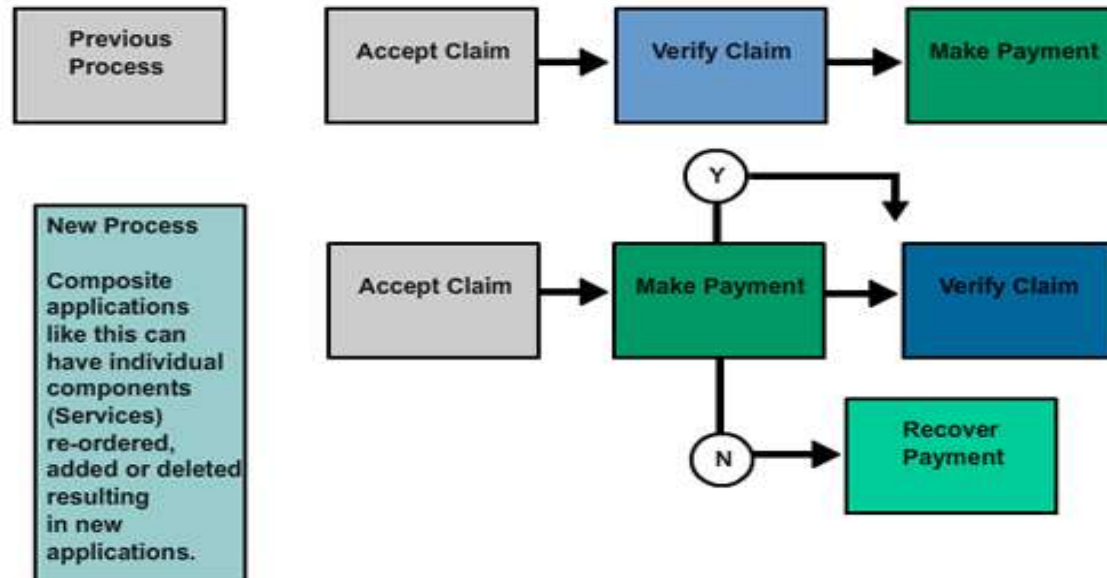

Page 12 of 13

© Copyright 2009 New York State Governor's Office of Employee Relations. All rights reserved.



Governor's Office of Employee Relations



New Online Offerings: Service Oriented Architecture

The screenshot shows a web-based learning interface. At the top left is the logo of the State of New York Governor's Office of Employee Relations. The page title is "Service-Oriented Architecture for New York State" and the location is "Online Learning Center". A navigation menu on the left includes "Introduction", "Overview", "Requirements", "Mapping", "Advantages", "Sharing", and "Module Review". The main content area is titled "Business Process Owners" and "Requirements: BPM External Agents". It contains a definition of external agents and a list of examples. To the right of the text is an illustration of a 3D white figure pointing at a whiteboard. At the bottom of the page, it says "Page 4 of 6" and "© Copyright 2009 New York State Governor's Office of Employee Relations. All rights reserved."

State of New York
Governor's Office of Employee Relations

Service-Oriented Architecture for New York State

Online Learning Center

EXIT

Introduction
Overview
Requirements
Mapping
Advantages
Sharing
Module Review

Business Process Owners

Requirements: BPM External Agents

External Agents – the persons, organizations, or system with which a business interacts. Sometimes called *actors*, external agents are commonly referred to as customers. In our example, the external agent is the person requesting the publication. In other instances, external agents might be:

- A student registering for a class.
- A retailer verifying a credit card.
- A concert-goer purchasing an online ticket.

Page 4 of 6

© Copyright 2009 New York State Governor's Office of Employee Relations. All rights reserved.



[www.goer.state.ny.us/Training_Development/
Online_Learning/index.cfm](http://www.goer.state.ny.us/Training_Development/Online_Learning/index.cfm)

June 11, 2010



DELIVERING EXCELLENCE



Non-Credit Programs — Continuing Education & Outreach

NON-CREDIT PRO

Have a Question or Problem with your Registration? [Click here to contact our](#)



**PSTP Courses
for NYS PS&T
Unit Employees**

Courses for New York State Employees in the Professional, Scientific and Technical (PS&T) Unit and Those Designated Management/Confidential (M/C)

We are pleased to announce the Governor's Office of Employees Relations (GOER) has partnered with Binghamton University to offer continuing education online courses free of charge to employees in the Professional, Scientific and Technical (PS&T) Unit and executive branch employees designated Management/Confidential (M/C). Course costs for PS&T Unit employees are made available in the negotiated Agreement between New York State and the Public Employees Federation. Course costs for M/C employees are paid from M/C training funds.

Course Information and Requirements:

The courses listed below are those approved for PS&T Unit and M/C designated employees. These courses are designed to meet your professional development needs and each provides 2.4 Binghamton University Continuing Education Unit credits. **be taken during working hours. No release time is provided.**



Training for the Future



June 13, 2010



Additional Questions? Have ideas for IT Training?

Contact Carolyn and Moses as follows:

cvaccaro@goer.state.ny.us

mkamya@goer.state.ny.us

**To assist with review of the SOA online class, contact
Debi Orton as follows:**

dorton@goer.state.ny.us